

## CliniMix® 1500 Lead Safe™ TMV in SS Cabinet with Seamless Removable Door

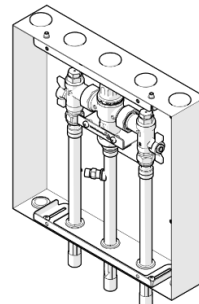

### PRODUCT CODES

- 201.40.70.10\*

\*Components in contact with water are identical as in 201.10.70.10 and are certified to WMKA 1593. The only difference in this item is the cabinet design.

### SPECIFICATIONS

- CliniMix® Thermostatic Mixing Valves are designed to protect users from scalding or cold water shock by providing tempered water to the desired outlets.
- This stainless steel cabinet is a lockable cabinet with 20mm copper fittings allowing secure installation and safe, simple maintenance of the thermostatic mixing valve.
- Flat faced connections allow removal of the valve without disturbing the pipework.
- In the event of either hot or cold water supply failure the valve will shut down.
- TMV's come complete with right angle isolating ball valve, non-return valve and strainer assemblies.
- Can be installed in any configuration with the water outlet in the horizontal or vertical position, and inlet connections can be rotated to suit inlet pipework.
- Complies with the requirements of AS/NZS 4032.1 – Thermostatic Mixing Valves.
- Components in contact with water are identical as in 201.10.70.10 and are certified to WMKA 1593. The only difference in this item is the cabinet design.

**WARNINGS:** Special attentions to be paid on notes, photos, images, or drawings of assembly steps marked with the warning symbol.



### TABLE OF CONTENTS

1.0 DESCRIPTION	2
2.0 TECHNICAL DATA	2
3.0 SAFETY	2
4.0 DIMENSIONS	3
5.0 FLOW SIZING GRAPH	4
6.0 WATER SUPPLY CONDITIONS	4
6.1 SCOPE OF USE	4
7.0 INSTALLATION	5
8.0 TROUBLESHOOTING	7
9.0 WARRANTY	8
10.0 APPENDIX	9

### 1.0 DESCRIPTION

This manual covers the CliniMix® 1500 Lead Safe™ TMV in SS Cabinet with Seamless Removable Door Assembly. This product is designed to provide tempered water to the desired outlets. This mixing valve cabinet assembly is supplied with integral isolating valves, strainers and check valves and is provided with a facility for thermal disinfecting of the cold inlet side and mixed water outlet.

Avoid using heat for soldering near the mixer inlets to prevent damage to internal components.

### 2.0 TECHNICAL DATA

#### MIXED OUTLET TEMPERATURE

Factory Preset Temperature (°C)	43 +/- 2
Adjustable Temperature Range (°C)	35 – 48

#### INLET TEMPERATURES

Cold Supply (°C)	Min	5
	Max	30
Hot Supply (°C)	Min	55
	Max	90
Hot to Mix Temp Differential (°C)	Min	10
Cold to Mix Temp Differential (°C)	Min	5
Nominal Flow Rate (LPM)	Min	4

#### DYNAMIC INLET PRESSURES

Hot and Cold Inlet Pressures	Min	20
	Max	600

#### STATIC INLET PRESSURE

Hot and Cold Inlet Pressures (kPa)	Max	1600
------------------------------------	-----	------

#### INLET PRESSURE RATIO

Supply Pressure Loss Ratio	Max	10:1
Recommended Supply Pressure Variation (Hot: Cold or Cold: Hot)		±10%
Minimum Flow Rate to Ensure Stable Operation		4 L/min

NOTE 1: For optimum operation it is recommended that the hot and cold water supply pressure be balanced to within +/- 10%

NOTE 2: Notwithstanding the above, compliance with AS/NZS3500 must be maintained.

### 3.0 SAFETY

The CliniMix® 1500 Lead Safe™ Thermostatic Mixing Valve is a high-performance valve designed to give stable and dependable operation, provided it is installed, commissioned, operated and maintained as per the recommendations outlined in this manual. It should be noted, however, that this valve should not be considered as an alternative to adequate supervision and duty of care during its use and operation.



**Note: The mixing valve, inlet controls, pipe work and the surrounding area may become hot when installed which may cause burn injuries. Precautions should be taken to ensure that these surfaces cannot cause such injuries.**

**4.0 DIMENSIONS**

- Cabinet to suit rough-in wall opening area 360mm width x 360mm height x minimum 75mm.
- Cabinet secured using back mount
- Measure and mark the cabinet mounting hole locations as per the dimensions shown in below mounting details image.

 Suitable fasteners will need to be sourced by the installer.

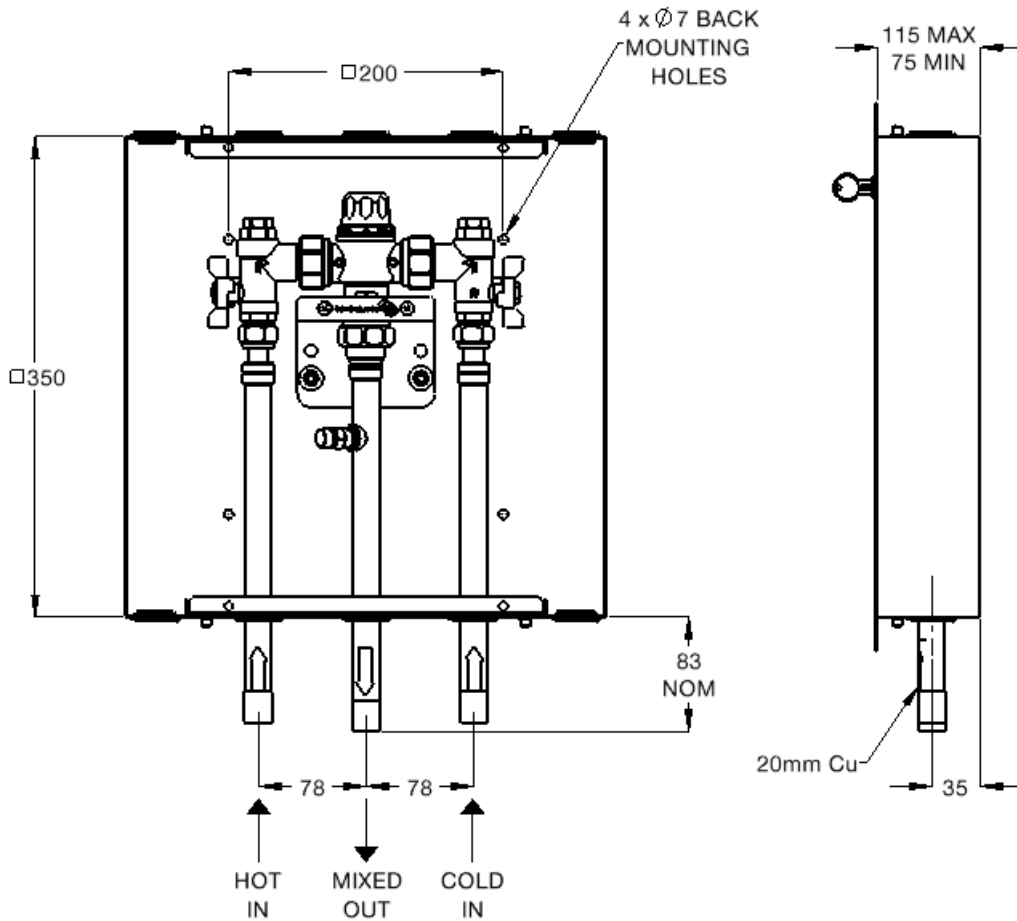

### 5.0 FLOW SIZING GRAPH

The Pressure Loss Characteristic for Mixed Outlet Flow rate versus Balanced Inlet Pressure is shown in the graph below. It is important that the valve is not oversized for its intended application.

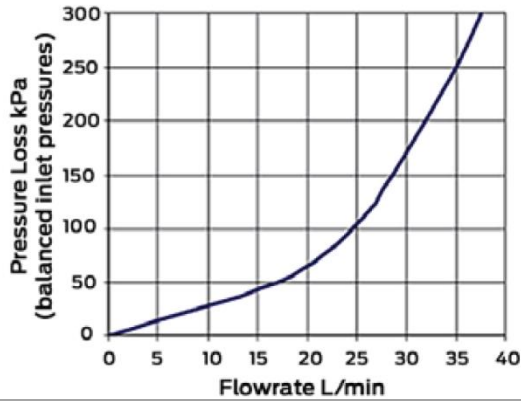

**NOTE:** To ensure optimum performance the minimum outlet flow of the TMV during operation should be at least 4 litres/minute.

It is important that the valve is sized such that the flow rates from the outlets are not less than those listed AS/NZS 3500.1

The pipe-work between the TMV and the system must be sized in accordance with AS/NZS 3500.1 to ensure the water velocity in the pipe-work is within the allowed limit.

If the TMV is to be installed and operated under unequal inlet pressures, the lower inlet pressure determines the outlet flow rate. However, for optimum performance and stability it is recommended that the TMV be installed with balanced dynamic inlet pressures (+/- 10%).

### 6.0 WATER SUPPLY CONDITIONS

#### 6.1 SCOPE OF USE

This mixing valve cabinet assembly is manufactured to the highest standards and uses AS4032.1 approved components which permits it to be installed in healthcare establishments such as hospitals, nursing homes and residential care homes. When installed in healthcare establishments the supply conditions detailed below must be observed and commissioning, maintenance, temperature adjustment, and on-going servicing provided in **201.70.11.09 Install** from [www.galvinengineering.com.au](http://www.galvinengineering.com.au) must be followed.

This mixer is designed to be installed on all types of plumbing systems.

For optimum operation it is recommended that the hot and cold water supply pressure be balanced to within +/- 10%.

The mixer has integral isolating valves which permit servicing of the strainer, check valve and thermostatic cartridge. They are also used for thermal disinfection.

If there is a risk that the dynamic inlet pressures exceed 600 kPa, a suitable pressure reducing valve must be fitted upstream of the inlet fitting.

If there is a risk that the hot water supply temperature exceeds 90°C, a suitable temperature limiting valve must be fitted upstream of the inlet fitting.

Working Temperature Range (°C)	Min	5
	Max	90
Working Pressure Range (kPa)	Min	20
	Max	600
Maximum Static Pressure (kPa)		1600
Permitted Supply Pressure Variation	Max	10:1

## 7.0 INSTALLATION

**INSTALLATION COMPLIANCE:** Galvin Engineering products must be installed in accordance with these installation instructions and in accordance with AS/NZS 3500, the PCA and your local regulatory requirements. Water and/or electrical supply conditions must also comply to the applicable national and/or state standards. Failing to comply with these provisions shall void the product warranty and may affect the performance of the product.

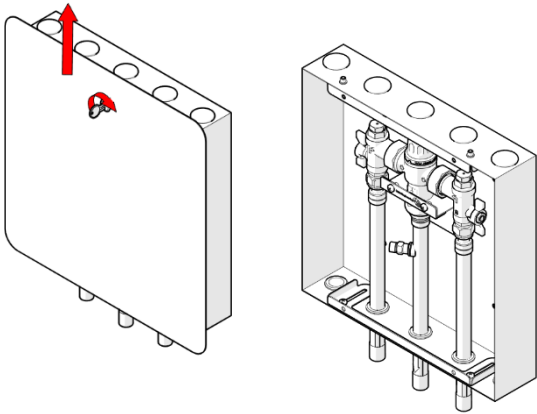

### 1. Remove cabinet door

- Unlock the cabinet door using the supplied door key then slide up to remove.

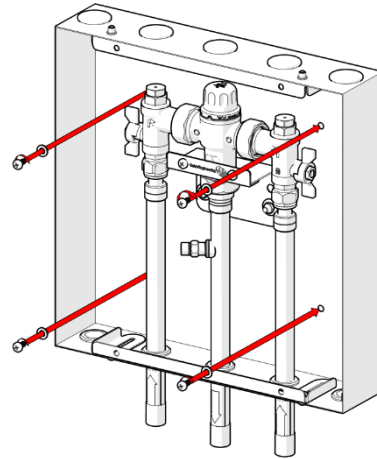

### 2. Secure the cabinet

- Insert cabinet into wall opening.
- Mount cabinet in wall using four fasteners, only securing hand tight.



**Note:** The cabinet must be mounted with four fasteners for stability and strength. This is critical, failure to do this may void the warranty.

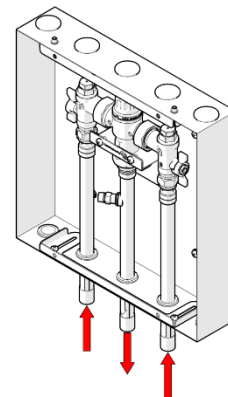

### 3. Connect water lines

- Before connecting to water lines, all lines must be flushed
- Remove protective vinyl cap from copper tubes.
- Join each copper tube to the correct main water line, taking note of flow direction arrows. Use suitable copper joining methods, ensuring no flash sits inside the pipeline, this will cause damage to the valves.



**Note:** The Galvin Engineering CliniMix Thermostatic Mixing Valve must be installed by a licensed plumber. If the valve is not installed correctly then it will not function correctly and may put the user in danger. It may also void the warranty of the valve.

<p><b>4. Adjust Cabinet Brackets</b></p> <ul style="list-style-type: none"> <li>– Adjust the brackets on the top and bottom of the cabinet to the distance required.</li> </ul>	<p><b>5. Testing and operation</b></p> <ul style="list-style-type: none"> <li>– Fit the door to the cabinet and lock using supplied key. Apply slight push on key when turning to facilitate locking function. Adjust the cabinet until the door sits flush with the wall then unlock and remove the door to completely tighten mounting fasteners.</li> <li>– Turn on hot and cold water supply.</li> <li>– Check for any leaks</li> <li>– Carry out commissioning procedure as per 201.70.11.09 installation instructions.</li> <li>– Check temperature of water is correct. If not, see temperature adjustment in <b>201.70.11.09</b> installation instructions available from <a href="http://www.galvinengineering.com.au">www.galvinengineering.com.au</a>.</li> <li>– Fit the door back to the cabinet and lock using supplied key. Apply slight push on key when turning to facilitate locking function. Ensure instructions are placed in the cabinet for future service and maintenance record.</li> </ul>

For commissioning, maintenance, temperature adjustment, spare parts and on-going servicing information refer to **201.70.11.09 Install** from [www.galvinengineering.com.au](http://www.galvinengineering.com.au).

**8.0 TROUBLESHOOTING**

PROBLEM	CAUSE	RECTIFICATION
The desired mixed water temperature cannot be obtained.	<ul style="list-style-type: none"> <li>- Hot and cold supplies are fitted to the wrong connections</li> <li>- Valve contains debris.</li> <li>- Strainers contain debris.</li> </ul>	<ul style="list-style-type: none"> <li>- Ensure the valve has the Hot/Cold supplies fitted to the correct connections.</li> <li>- Clean valve ensuring debris is removed and components are not damaged.</li> <li>- Clean strainers ensuring debris is removed.</li> <li>- Check non return device is not jammed. Clean if necessary.</li> </ul>
The valve will not shut down during testing.	<ul style="list-style-type: none"> <li>- The hot to mix temperature differential is not high enough.</li> <li>- Sealing seat is damaged or fouled by debris</li> </ul>	<ul style="list-style-type: none"> <li>- Raise hot water temperature.</li> <li>- Replace piston O-rings</li> <li>- Clean seat.</li> <li>- Replace element assembly</li> </ul>
Mix temperature unstable.	<ul style="list-style-type: none"> <li>- Debris is fouling valve.</li> <li>- Flow rate below 4 L/min.</li> <li>- Strainers are fouled.</li> <li>- Systems may be fluctuating outside valve parameters</li> </ul>	<ul style="list-style-type: none"> <li>- Clean the valve ensuring that all debris is removed and components are not damaged.</li> <li>- Rectify any pressure deterioration.</li> <li>- Clean strainers</li> <li>- Check system pressure; install pressure control valves to ensure inlet conditions are within limit</li> </ul>
Mix temperature changing over time.	<ul style="list-style-type: none"> <li>- Inlet conditions (pressures or temperatures) are fluctuating,</li> <li>- Strainers contain debris.</li> </ul>	<ul style="list-style-type: none"> <li>- Install suitable pressure control valves to ensure inlet conditions are within range.</li> <li>- Clean strainers ensuring debris is removed.</li> </ul>
Either full hot or cold flowing from the outlet fixture.	<ul style="list-style-type: none"> <li>- Valve is incorrectly set.</li> <li>- Hot/Cold water has migrated to other inlet.</li> </ul>	<ul style="list-style-type: none"> <li>- Adjust mix temperature between 35 – 48 Degrees Celsius as required.</li> <li>- Replace faulty non-return valves</li> </ul>
No flow from the valve outlet.	<ul style="list-style-type: none"> <li>- Hot or cold water failure.</li> <li>- Strainers are fouled</li> </ul>	<ul style="list-style-type: none"> <li>- Valve functioning correctly. Restore inlet supplies and check mix temperature.</li> <li>- Clean strainer.</li> </ul>
Flow rate reduced or fluctuating	<ul style="list-style-type: none"> <li>- Valve or inlet fittings fouled by debris.</li> <li>- Dynamic inlet pressures are not within those recommended limits.</li> </ul>	<ul style="list-style-type: none"> <li>- Check valve and inlet fittings for blockages.</li> <li>- Ensure the dynamic inlet pressures are nominally balanced to within +/- 10%</li> </ul>
Mixed water temperature too hot or cold.	<ul style="list-style-type: none"> <li>- Valve has been tampered with.</li> <li>- Valve incorrectly set.</li> <li>- Inlet temperatures are not within specified limits.</li> </ul>	<ul style="list-style-type: none"> <li>- Readjust valve to required set temperature.</li> <li>- Readjust valve to required set temperature.</li> <li>- Ensure inlet temperatures are within the specified limits.</li> </ul>
Valve is noisy.	<ul style="list-style-type: none"> <li>- Water velocity above velocity requirements of AS3500.1.</li> </ul>	<ul style="list-style-type: none"> <li>- Reduce water velocity.</li> </ul>

## 9.0 WARRANTY

Galvin Engineering products are covered under our Manufacturer's Warranty. Galvin Engineering products must be installed in accordance with the installation instructions and in accordance with AS 3500 and NCC Volume Three, relevant Australian Standards and local authorities applicable to product being installed. Water and electrical supply conditions must also comply to the applicable national and/or state standards, failing to comply with these provisions may void the product warranty and affect performance of the product.

Please visit [www.galvinengineering.com.au](http://www.galvinengineering.com.au) to view the full warranty, our Installation Compliance and Maintenance & Cleaning information as well as any other additional information.



**10.0 APPENDIX**

# Galvin Engineering Thermostatic Mixing Valve Commissioning Report and/or Maintenance Report

Note:

1. Please use a separate form for each valve.
2. The original copy of the report is to be given to the owner/occupier and retained on site for a minimum of 7 years.

Cross off appropriate box

Thermostatic Mixing Valve

Commissioning Report  Maintenance Report

Name of Establishment: \_\_\_\_\_

Address of Establishment: \_\_\_\_\_

Phone Number: \_\_\_\_\_ Date: \_\_\_\_\_ Work Order #: \_\_\_\_\_

Contact Person: \_\_\_\_\_ Make & Model of Hot Water System: \_\_\_\_\_

Temperature of Hot Water to the Valve: \_\_\_\_\_ Temperature of Cold Water to the Valve: \_\_\_\_\_

Hot Water Pressure: \_\_\_\_\_ kPa Cold Water Pressure: \_\_\_\_\_ kPa

Make of Mixing Valve: \_\_\_\_\_ Model No: \_\_\_\_\_ Size: \_\_\_\_\_

Valve Location/Building: \_\_\_\_\_

Valve Identification No: \_\_\_\_\_

Total No of Valves on the Site/Building: \_\_\_\_\_

No of Outlets Serviced by this Valve: Baths ( ) Basins ( ) Showers ( )

Other Outlets - Details \_\_\_\_\_

Valves Installed to the requirements of:

The NSW Code of Practice Plumbing and Drainage	Yes	No
The HOSPLAN Code of Practice for Thermostatic Mixing Valves in Health Care Facilities	Yes	No
The Valves manufacturers requirements	Yes	No
AS4032.3	Yes	No
The specifications and drawings for the project	Yes	No
The Local Water Supply or Authority	Yes	No

If No, give details and actions taken:

\_\_\_\_\_

\_\_\_\_\_

\_\_\_\_\_

# Galvin Engineering Thermostatic Mixing Valve Commissioning Report and/or Maintenance Report

## Test Results

Valve considered satisfactory for use: Yes  No

If No, state the reason and action taken:

---

---

---

## Commissioning Work

It is hereby certified that all the commissioning work has been carried out by the undersigned in accordance with the requirements of the Codes of Practice indicated prior.

Date of Valve Commissioned: \_\_\_\_\_

Name of Licensed Plumber: \_\_\_\_\_ License/Cert No: \_\_\_\_\_

License Plumbers Signature: \_\_\_\_\_

Telephone No. \_\_\_\_\_

Owner/occupiers signature: \_\_\_\_\_ Date: \_\_\_\_\_

Date of Initial Service Due: \_\_\_\_\_

# Galvin Engineering Thermostatic Mixing Valve Commissioning Report

Valve Location/Building : \_\_\_\_\_

Room or Area: \_\_\_\_\_

Work Order No.: \_\_\_\_\_

Warm Water Outlet Fixture No.	*Name/Type/Size and location of Outlet Fixture (Bath, Shower, Basin, Other)	Flow rate of Design Water (LPS)		Temp of Warm Water (C)	
		One Outlet in Use	**All Req'd Outlets in Use	One Outlet in Use	**All Req'd Outlets in Use
1.					
2.					
3.					
4.					
5.					
6.					
7.					
8.					
9.					
10.					
11.					

\*Give details of brand and model designation.

\*\* Commensurate with the design flow rate for the mixing valve.

Note: An accurate digital thermometer is necessary for the temperature measurements

Prescribed temperature range for warm water \_\_\_\_\_ C to \_\_\_\_\_ C

Thermal shutdown at both minimum and maximum design flow rates

(Passed/Failed) Yes  No  Name of Plumber: \_\_\_\_\_

License/Cert No. \_\_\_\_\_

Licensee's Signature: \_\_\_\_\_ Date: \_\_\_\_\_

Telephone Number: \_\_\_\_\_

# Galvin Engineering Thermostatic Mixing Valve Commissioning/Maintenance Report

The following information is to be provided by the site manager/owner/occupier.

Valve size and installation recommended by : \_\_\_\_\_

Valves supplied by: \_\_\_\_\_

Date of Installation: \_\_\_\_\_ Drawing No. \_\_\_\_\_

Service Manual on Site: Yes  No

Commissioning Tests for new installation or valve replacement. Yes

This set of testing procedures and report received and witnessed by (Print Name): \_\_\_\_\_

Temperature setting at completion of commissioning \_\_\_\_\_ C

Position: \_\_\_\_\_ Signature: \_\_\_\_\_

Date: \_\_\_\_\_

**Maintenance Tests. Yes**

Date of Previous Service: \_\_\_\_\_

Previous Service carried out by: \_\_\_\_\_

Reason for Maintenance Tests: \_\_\_\_\_

This Test and report Witnessed by: \_\_\_\_\_

The valve has been operating/performing satisfactorily for the previous 12 months: Yes  No

Comment on monthly Temperature Tests carried out by the owner \_\_\_\_\_

Temperature setting at time of completion: \_\_\_\_\_ C

Current Report received and witnessed by:

Name: \_\_\_\_\_

Position: \_\_\_\_\_

Signature: \_\_\_\_\_ Date: \_\_\_\_\_